

Helium gas permeability of SiC/SiC composite after heat cycles

T. Hino ^{a,*}, E. Hayashishita ^a, A. Kohyama ^b, Y. Yamauchi ^a, Y. Hirohata ^a

^a *Laboratory of Plasma Physics and Engineering, Hokkaido University, Sapporo, 060-8628, Japan*

^b *Institute of Advanced Energy, Kyoto University, Uji, 611-0011, Japan*

Abstract

In a blanket made of SiC/SiC composite, helium gas employed as coolant may leak into plasma, resulting in fuel dilution. The helium gas permeability of SiC/SiC composite has to be measured to qualify SiC/SiC composite as a blanket material. Since the SiC/SiC blanket receives heat cycles due to plasma start up and shut down phases, the change of helium gas permeability after the heat load has to be investigated. Heat cycles with different highest temperatures and heating rates were applied to SiC/SiC composite with very low permeability, and the change of permeability was measured. No increase in the permeability was observed for an operation temperature of SiC/SiC blanket at 1100 K. The increase of permeability was observed only when the maximum temperature was very high, 1300 K, and when the heating rate was also large, 10 K/s. The operational regime without increase of permeability was determined based upon the present data.

© 2007 Elsevier B.V. All rights reserved.

1. Introduction

The use of low activation materials is planned for blankets and plasma facing walls of fusion demonstration reactors, and the technical feasibilities have been investigated. For low activation materials, the candidate materials are ferritic steel [1], vanadium alloy [2] and SiC/SiC composite [3]. The effects of neutron damage on the changes of mechanical and thermal properties have been well investigated so far. In particular, the operation temperature regime determined by ductile-brittle transition temperature and creep occurrence temperature of ferritic steel

and vanadium alloy has been well discussed. Since these materials are used also for first wall and/or plasma facing wall, the influences of blankets made by these materials on fusion plasmas have to be investigated.

For blankets made of SiC/SiC composite [4], a high energy conversion efficiency is expected since the coolant outlet temperature can be high, approximately 1100 K. High pressure helium gas is employed as the coolant in this blanket. SiC/SiC composite is a ceramics material, so a concern is the leaking of helium gas into the fusion plasma. The leak rate has to be lower than the helium production rate by fusion reactions in order to avoid fuel dilution [5,6].

Numerous SiC/SiC composites have been developed for fusion application by the group of Kyoto University and Ube Industries [7]. The helium gas permeabilities of these SiC/SiC composites were

* Corresponding author. Present address: Laboratory of Plasma Physics and Engineering, Hokkaido University, Kita-13, Nishi-8, Kita-ku, Sapporo, 06-8618, Japan. Tel.: +81 11 706 7194; fax: +81 11 709 6413.

E-mail address: tomhino@qe.eng.hokudai.ac.jp (T. Hino).

measured at Hokkaido University using a vacuum apparatus consisting of two chambers. The SiC/SiC composite recently developed by the NITE process showed a very low permeability [5,6]. This result suggests that the blanket can be produced using only the SiC/SiC composite if the helium leaking into a plasma is reduced by vacuum pumping attached to the blanket module. However, there is another concern on the permeability. The blanket module receives heat cycles owing to start up and shut down of the fusion reactor. Hence, the change or increase of the permeability due to the heat cycles has to be investigated. In our previous study, the permeability of the SiC/SiC composite with relatively porous structure remained the same even after heat cycles [6]. The permeability of the SiC/SiC composite with a dense structure, however, increased several times after the heat cycles with temperature higher than the operation temperature, 1100 K. These results suggest that the heat load condition has to be suitably chosen in the use of SiC/SiC composite based blankets.

In the present study, the helium gas permeability is measured for numerous SiC/SiC composites. The permeability is also measured for the SiC/SiC composite with a dense structure and very low permeability, following exposure to heat loads with different cycle numbers, maximum temperatures and heating rates. The operation regime without increase of permeability is discussed.

2. Experiments

Helium gas permeabilities were measured for SiC/SiC composite samples made by several methods, HP: hot pressing, PIP: polymer infiltration and pyrolysis, PIP + MI: PIP and melt infiltration, NITE: nanopowder infiltration and transient eutectoid. For the samples made by the NITE process, three SiC/SiC composites (NITE commercial, NITE lab.(M/N), NITE lab.(N)) and bulk SiC (NITE bulk) were employed. The SiC/SiC composites except HP consist of two layers, SiC fiber bundle layer and SiC matrix layer. The fiber bundle layer consists of unidirectional SiC fiber bundles with SiC matrix. For the SiC fiber, Tyranno SA fiber tows coated by pyrolytic carbon (Ube Industries) were used. The sample of HP consists of only fiber bundle layers with Tyranno SA fiber. The samples made by HP, PIP and PIP + MI have relatively large pore structures, so that the permeability was observed to be large, as shown in Fig. 2. The bulk

SiC (NITE bulk) was made using only nanopowder of β -SiC. The nanopowder of β -SiC was used for the matrix layer in every SiC/SiC composite sample made by NITE process. The nanopowder of β -SiC was used for the matrix of the fiber bundle layer in NITE lab.(N). On the other hand, micro powder of β -SiC was used for the matrix of the fiber bundle layer in NITE commercial and NITE lab.(M/N). NITE commercial is a commercial pilot grade of NITE lab.(M/N). The shape of every sample was a flat plate with a size of $15 \times 15 \times 2$ mm.

The helium gas permeability was measured using a vacuum device consisting of two chambers, high pressure chamber and low pressure chamber, as shown in Fig. 1. The sample was fixed on a stainless steel pipe between two chambers using a vacuum seal of epoxy resin. The sample temperature was at room temperature. The direction of helium gas flow was taken perpendicular to the fiber bundle and matrix layers. The low and high pressure chambers were evacuated using diffusion and rotary pumps. The pressure in the high pressure chamber was adjusted using mass flow controller (MFC), ionization gauge (IG) and mercury manometer (UM). The pressure was taken in the range from 10^2 to 5×10^5 Pa. The pressure increasing in the

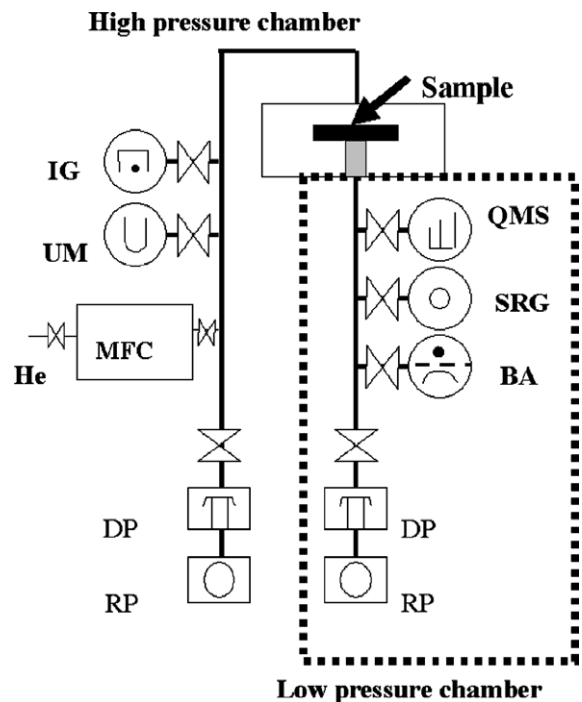

Fig. 1. Schematic of the apparatus of helium gas permeability measurement.

low pressure chamber was measured after the adjustment of the pressure in the high pressure chamber. Since the range of the pressure rise is very broad, numerous vacuum gauges, spinning rotor gauge (SPR), BA ionization gauge (BA) and quadruple mass spectrometer (QMS), were used according to the pressure rise. The helium gas permeability, K (m^2/s), was determined using

$$K = P_L d S_{\text{eff}} / P_H A, \quad (1)$$

where P_L and P_H are pressures rise in the low pressure chamber and the pressure in the high pressure chambers, respectively, d and A are thickness and area of sample, and S_{eff} is the effective pumping speed in the low pressure chamber. Eq. (1) is applied if the helium flow is a molecular flow, not a viscous flow. In this case, the permeability becomes constant for the pressure in the high pressure chamber.

The heat load was applied using a resistive heating for a tantalum container with the sample in the other vacuum device. The highest temperature in the surface facing the Ta container was taken in the range from 1000 to 1400 K. The heating rate was taken 6, 8 and 10 K/s and the holding time at the highest temperature was 5 min. The number of heat cycles was as large as 120. After the heat cycles, the sample was transferred to the permeability measurement device.

3. Results

The permeability was measured for numerous SiC/SiC composites before imposing the heat load. Fig. 2 shows a plot of the helium gas permeability against the pressure in the high pressure chamber.

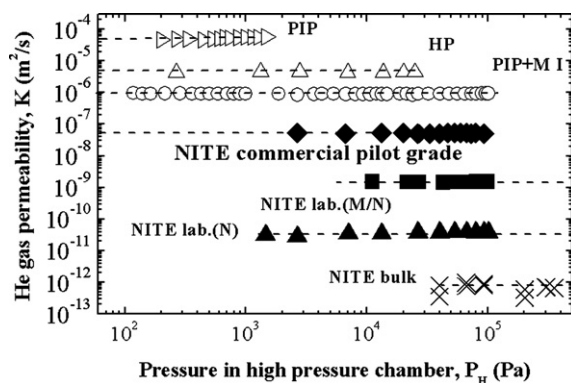

Fig. 2. Helium gas permeability versus pressure in high pressure chamber for various SiC/SiC composites.

The permeability was approximately constant to the pressure in the high pressure chamber. The samples made by PIP, HP and PIP + MI had relatively high permeability, 10^{-6} – 10^{-4} m^2/s . The surface morphologies of these samples were observed using scanning electron microscope (SEM). Micron size pores were observed in these samples. In the samples made by NITE process, the permeability was low, in the range from 10^{-13} – 10^{-7} m^2/s . The bulk SiC, NITE bulk, made by only nanopowder of β -SiC, had the lowest permeability. As the SiC/SiC composite, NITE lab.(N) using only nanopowder of β -SiC for the matrix both in the fiber bundle layer and matrix layer, had a lowest permeability, 10^{-11} m^2/s . NITE lab.(M/N) or NITE commercial had the permeability several order of magnitude higher than that of NITE lab.(N).

The permeability was measured for NITE commercial after heat cycles. The permeability of NITE commercial before the heat load depended on the sample, and the permeability was in the range of 4×10^{-8} to 10^{-7} m^2/s . The heat cycles with highest temperature from 1000 to 1300 K and heating rate from 6 to 10 K/s was applied. The increase of the permeability was not observed for the heat load with heat cycles of 120, highest temperature of 1200 K and heating rate of 10 K/s. The increase of the permeability was observed only when the number of heat cycle was 120 at the highest temperature of 1300 K and heating rate of 10 K/s. Fig. 3(a) and (b) shows the helium gas permeability versus pressure in the high pressure chamber for the cases with heating rate of 10 K/s and highest temperatures of 1200 K and 1300 K, respectively. Fig. 4 shows the increasing ratio of the permeability, $\Delta K/K$, versus number of heat cycle, for different highest temperatures, T_{max} , when the heating rate was 10 K/s. Here, ΔK is the increase of permeability after the heat cycles. Fig. 5 shows the increasing ratio of permeability versus number of heat cycle for different heating rate when the highest temperature was 1300 K. In the case of 1300 K and 10 K/s, the increasing ratio of permeability was approximately 1.6. The highest temperature was increased to 1400 K, and the increase of the permeability was measured after 120 heat cycles. In every case, an increase of the permeability was observed. Fig. 6 shows the region without increase of permeability in a diagram of maximum temperature versus heating rate. In this figure, open circle and cross show no increase and increase in permeability, respectively. This figure is useful to design the maximum

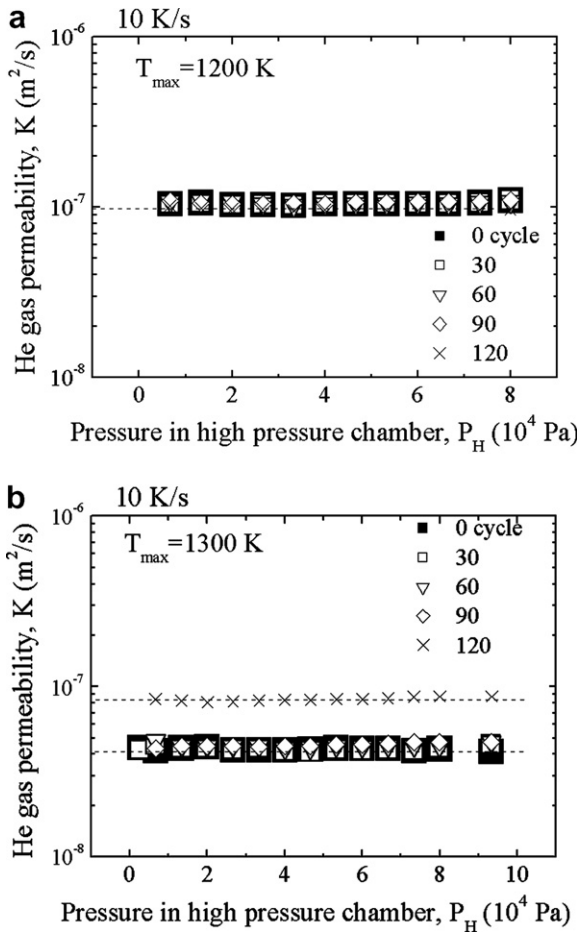

Fig. 3. Helium gas permeability of SiC/SiC composite, NITE commercial, versus pressure in high pressure chamber, after heat cycles with heating rate of 10 K/s and maximum temperatures of 1200 K (a) and 1300 K (b).

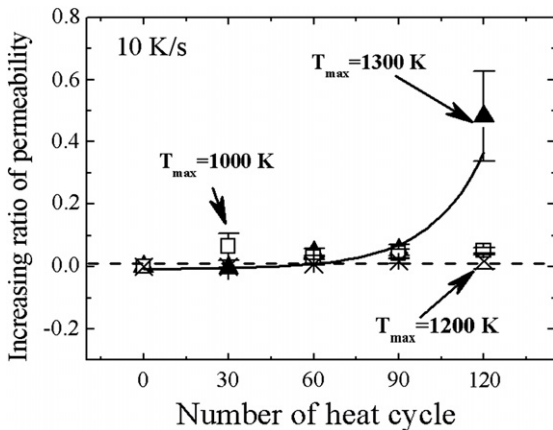

Fig. 4. Ratio of helium gas permeability versus number of heat cycles for heating rate of 10 K/s and different maximum temperatures.

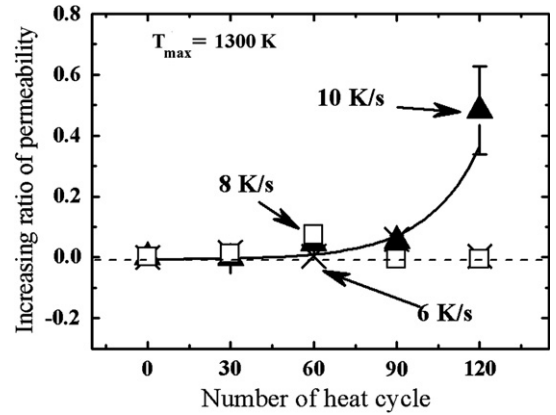

Fig. 5. Ratio of helium gas permeability versus number of heat cycles for maximum temperature of 1300 K and different heating rates.

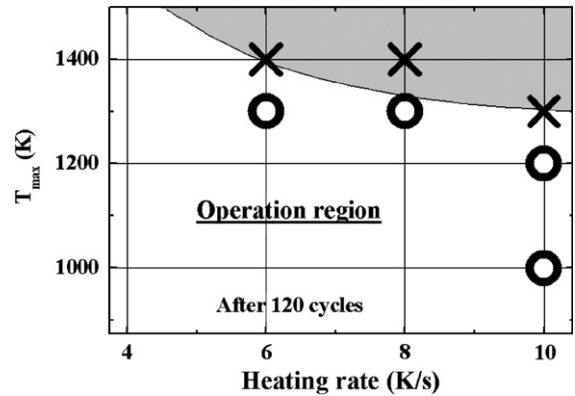

Fig. 6. Operation region of SiC/SiC composite blanket in diagram of maximum temperature and heating rate. Here, open circle and cross show no increase and increase in permeability, respectively. The maximum pressure is $5 \times 10^5 \text{ Pa}$.

operation temperature and the heating or cool down rate of the SiC/SiC composite blanket. The increase of permeability is easily avoided if the operation temperature is 1100 K.

In order to consider the reason for increase of permeability, the surface morphologies of the sample before and after the heat load were observed using scanning electron microscope. Fig. 7 shows the parts of fiber bundle and matrix layers after 120 heat cycles with highest temperature of 1300 K and heating rate of 10 K/s. After the heat cycles, the matrix in the fiber bundle layer was lost, and the matrix with a micron size in the matrix layer was lost. The small fragments remained on the

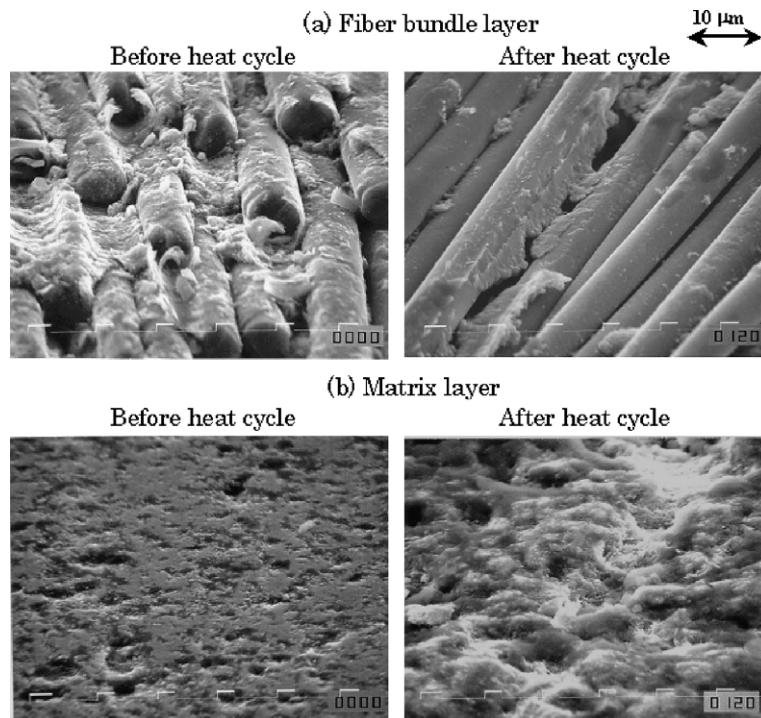

Fig. 7. Surface morphologies of fiber bundle layer (a) and matrix layer (b) before and after 120 cycles, maximum temperature of 1300 K, and heating rate of 10 K/s.

tantalum container were also observed using SEM. The size of the lost piece or fragment was in the range from 1 to 100 μm. Most of the fragments had a size from 2 to 8 μm. The cracking might have been caused by the thermal stress during the heat load since the degree of thermal expansion both in the matrix and the fiber bundle layers is not isotropic and/or different.

In order to apply the SiC/SiC composite to a blanket, one of the concerns is the leaking of helium gas coolant into a fusion plasma. The leak rate has to be lower than the helium production rate by fusion reactions to avoid the fuel dilution. For this sake, the blanket module has to be evaluated to reduce the helium pressure inside of the module, and the heating or cooling down temperature rate has to be suitably chosen to avoid the increase of helium gas permeability.

4. Conclusion

The helium gas permeability was measured for the candidate blanket material of SiC/SiC composite prepared by the NITE process, following heat cycling with the number of heat cycles up to 120,

highest temperature during a heat cycle up to 1400 K, and heating rates up to 10 K/s. The increase of the permeability was observed under the severe condition of highest temperature of 1300 K, heating rate of 10 K/s and number of heat cycles of 120. Matrix material with a micron size matrix material was lost both in the fiber bundle and the matrix layers due to the thermal stress. The temperature operation map with no increase of permeability, at highest temperature and heating or cooling down temperature rate, was obtained.

The operation temperature of the SiC/SiC composite blanket is regarded to be 1100 K, so that an increase of permeability can be avoided if the heating or cooling rate is suitably chosen.

References

- [1] T. Hino, K. Yamaguchi, Y. Yamauchi, et al., *Plasma Sci. Technol.* 7 (2005) 2737.
- [2] T. Hino, Y. Hirohata, Y. Yamauchi, S. Sengoku, Low activated material as plasma facing components, IAEA-CN-77/FTP1/08, in: 18th IAEA Fusion Energy Conference, Sorrento, Italy, 2000.
- [3] A. Kohyama, Y. Katoh, S.M. Dong, T. Hino, SiC/SiC composite for fusion by NITE process and its performance,

- FT/P1-02, in: 19th IAEA Fusion Energy Conference, Lyon, France, 2002.
- [4] C.P.C. Wong, S. Malang, S. Nishio, R. Raffray, A. Sagara, *Fusion Eng. Des.* 61&62 (2002) 283.
- [5] T. Hino, T. Jinushi, Y. Hirohata, M. Hashiba, Y. Katoh, A. Kohyama, *Fusion Sci. Technol.* 43 (2003) 184.
- [6] T. Hino, E. Hayashishita, Y. Yamauchi, M. Hashiba, *Fusion Eng. Des.* 73 (2005) 51.
- [7] A. Kohyama, M. Kotani, Y. Katoh, T. Nakayasu, M. Sato, T. Yamamura, K. Okamura, *J. Nucl. Mater.* 283–287 (2000) 565.